

FRONT VIEW

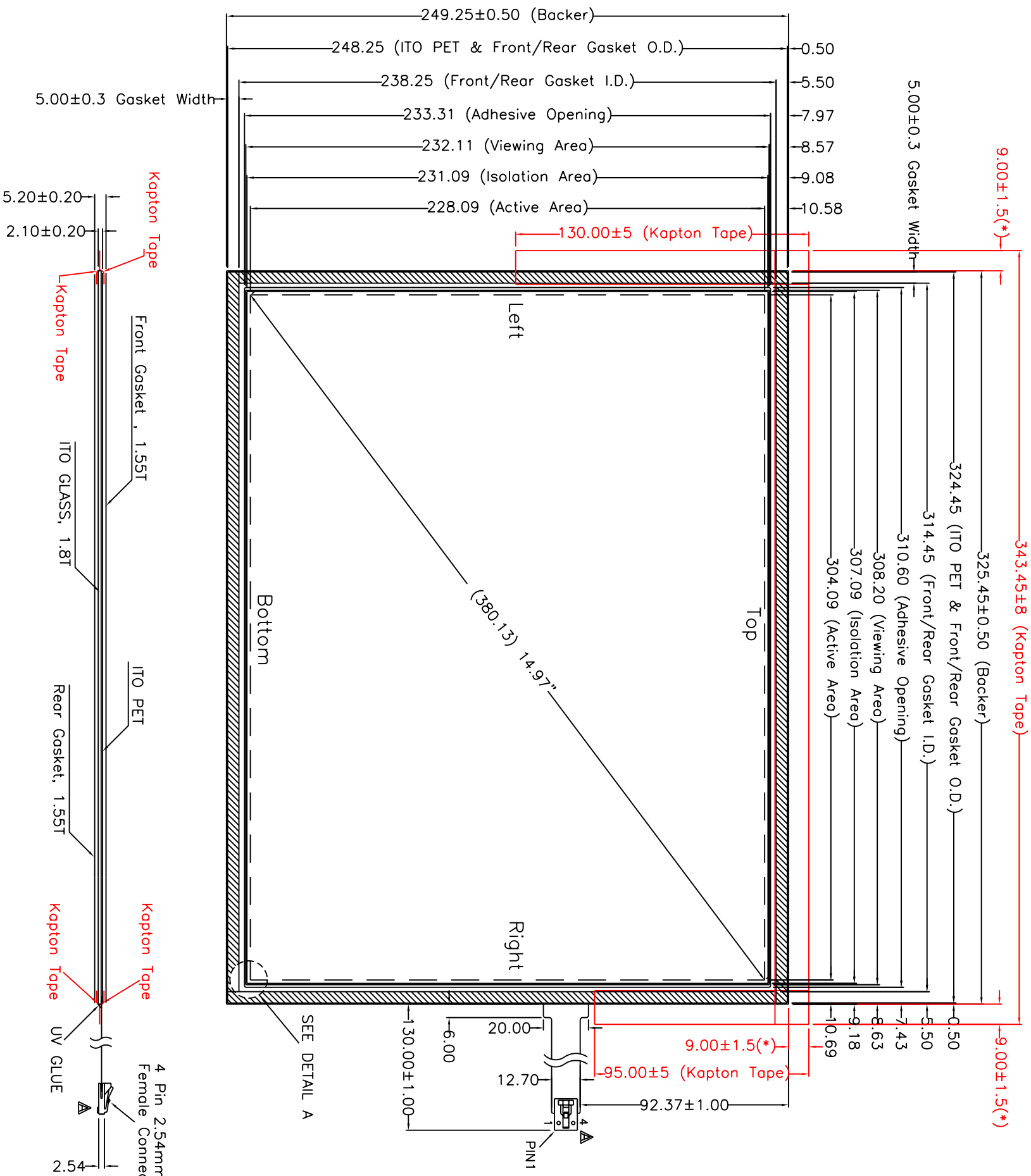

| Pin # | Assignment |
|-------|------------|
| 1 | Bottom |
| 2 | Right |
| 3 | Top |
| 4 | Left |

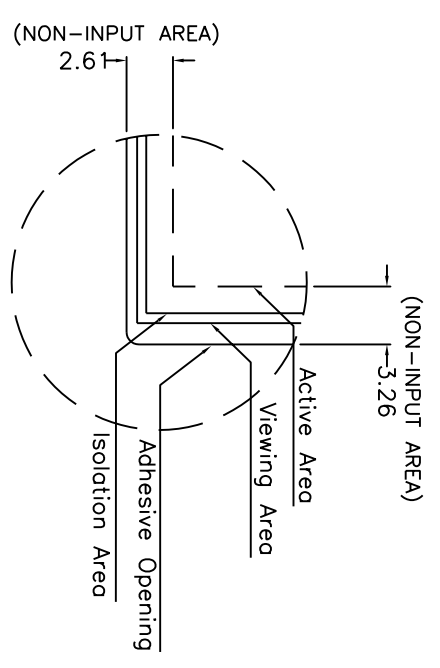

NOTES:

1. ITO GLASS THICKNESS : 1.80mm
2. OVERALL THICKNESS : 5.20±0.20mm (W/KAPTON TAPE & GASKETS INCLUDED) REFERENCE ONLY
3. CONNECTOR AND PINOUT AS INDICATED
4. FRONT SURFACE : ANTI-GLARE HARDCOAT
5. LAYER TO LAYER ASSEMBLY TOLERANCE: ±0.50mm
6. TAIL TYPE : IMMERSION GOLD PLATED FPC WITH AMP-C (WITH LATCH) CONNECTOR
7. KAPTON TAPE WIDTH : 15mm
8. (*) KAPTON TAPE OUTSIDE THE BACKER
9. OTHER SPEC : SEE APPROVAL SHEET



| NO. | DATE | REVISION | DESCRIPTION | CHK |
|-----|-------------|-----------------------------------|-------------|------|
| A | Mar 8, 2007 | AMP-C Connector With Latch Modify | | ALEX |

Apex Material Technology Corp.

| CHIEF OF DESIGN | APPROVED | PROJECT MANAGER | DATE | REV. | SCALE: | UNIT: |
|-----------------|----------|-----------------|-------------|------|---------|-------|
| Jerry | Alex | Jerry | MAR 9, 2007 | A | ANGULAR | mm |

PROJECT NAME : 9543-2
 DWG NO : 9543-2-1-01
 SCALE: UNIT: mm