

PDX2-090T



FEATURES

- 9" TFT LCD with Resistive Touchscreen
- DM&P Vortex86DX2-933MHz Onboard
- 1GB/ 2GB DDR2 System Memory Onboard
- Fanless and Low Power Consumption
- Metal Chassis with Compact Design
- CF Card, Micro SD slot (Optional)
1G / 2G Flash Memory onboard (Optional)



CE

FCC

VCCI

VIBRATION

IP 65

TOUCH

Wi-Fi

FANLESS

SPECIFICATION

LCD Display	Type	WSVGA TFT LCD
	Size	9"
	Resolution (Pixel)	1024(W) x 600(H)
	Colors	262,144
	View Angle	Vertical 120° / Horizontal 140°
	Brightness	300 cd/m2
	Backlight Life	18,000 hrs
	Contrast Ratio	500 : 1
CPU	DM&P Vortex86DX2-933MHz	
Cache	L1: 16KB I-Cache, 16KB D-Cache / L2: 256KB Cache	
Memory	1GB / 2GB DDR2 Memory Onboard	
Watchdog Timer	Software Programmable from 30.5u to 512 Seconds x 2 Sets	
Serial Port	RS-232 / 422 / 485 x 1	
USB Ports	USB Ports (Version 2.0) x 2	
Ethernet	Integrated 10/100M Ethernet	
Audio	HD Audio-Realtek ALC262 CODEC	
Internal Drives	CF Card; Micro SD slot, 1G / 2G Flash Memory onboard (Optional)	
Touch Screen Type	Analog Resistive	
Expansion Slot	None	
Power Requirement	Single Voltage +5VDC (5A)/ Multi Voltage +8~+35VDC (8A)	
Power Consumption	20W (Max.)	
Operating Temperature	0~+50°C (32~+122°F) / -20~+60°C (-4~+140°F) Optional & CPU down to 800MHz (-I)	
Storage Temperature	-30~ +70°C (14 ~+158°F)	
Operating Humidity	0% ~ 90% Relative Humidity, Non-Condensing	
Operating System	Linux, Win CE, Win XP, Win 7, Windows Embedded Standard	
Dimensions	236.6x146x35mm (9.31x5.75x1.38 inches) -	
Weight	790g	
Certificate	CE / FCC / VCCI / Vibration / Shock / IP65 (Front Panel)	

DIMENSIONS

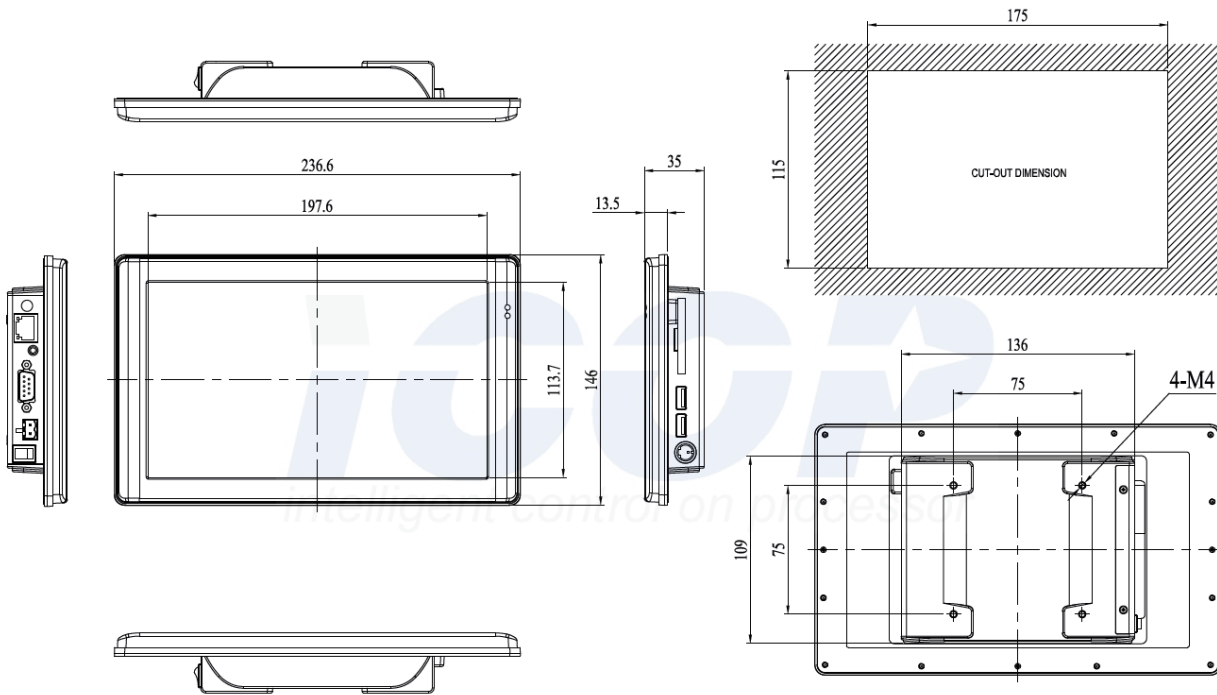

Unit: mm

I/O Overview

PDX2-090T Right site

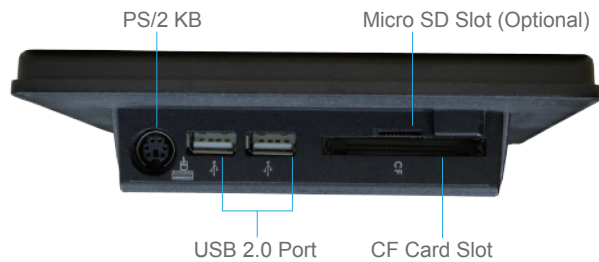

PDX2-090T-Left site

PDX2-090T-5A

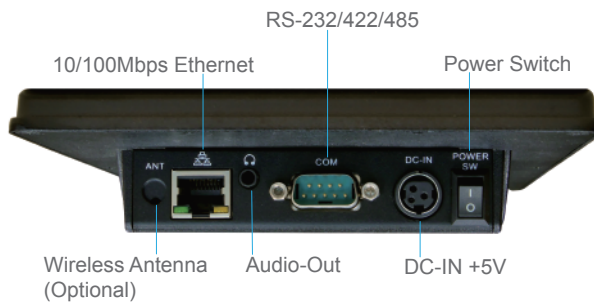

PDX2-090T-8A

